

**NEW FROM KURT**  
***DX6™ CrossOver™***



**THE BEST “D” SERIES VISE WE HAVE EVER MADE**



# DX6™ CrossOver™ Vise

## INTRODUCING THE KURT DX6™ CrossOver™ Vise

The evolutionary DX6™ CrossOver™ Vise combines all the great features of the world-renowned KURT D688 and 3600V vises, along with new state-of-the-art workholding features. DX6™ CrossOver™ achieves new levels in precision and performance where flatness and parallelism are important and is a better vise than our own D688 in every way we measure a vise. With KURT'S **MADE IN AMERICA** commitment, the DX6™ CrossOver™ is destined to become the go-to-vise for today's machining applications.

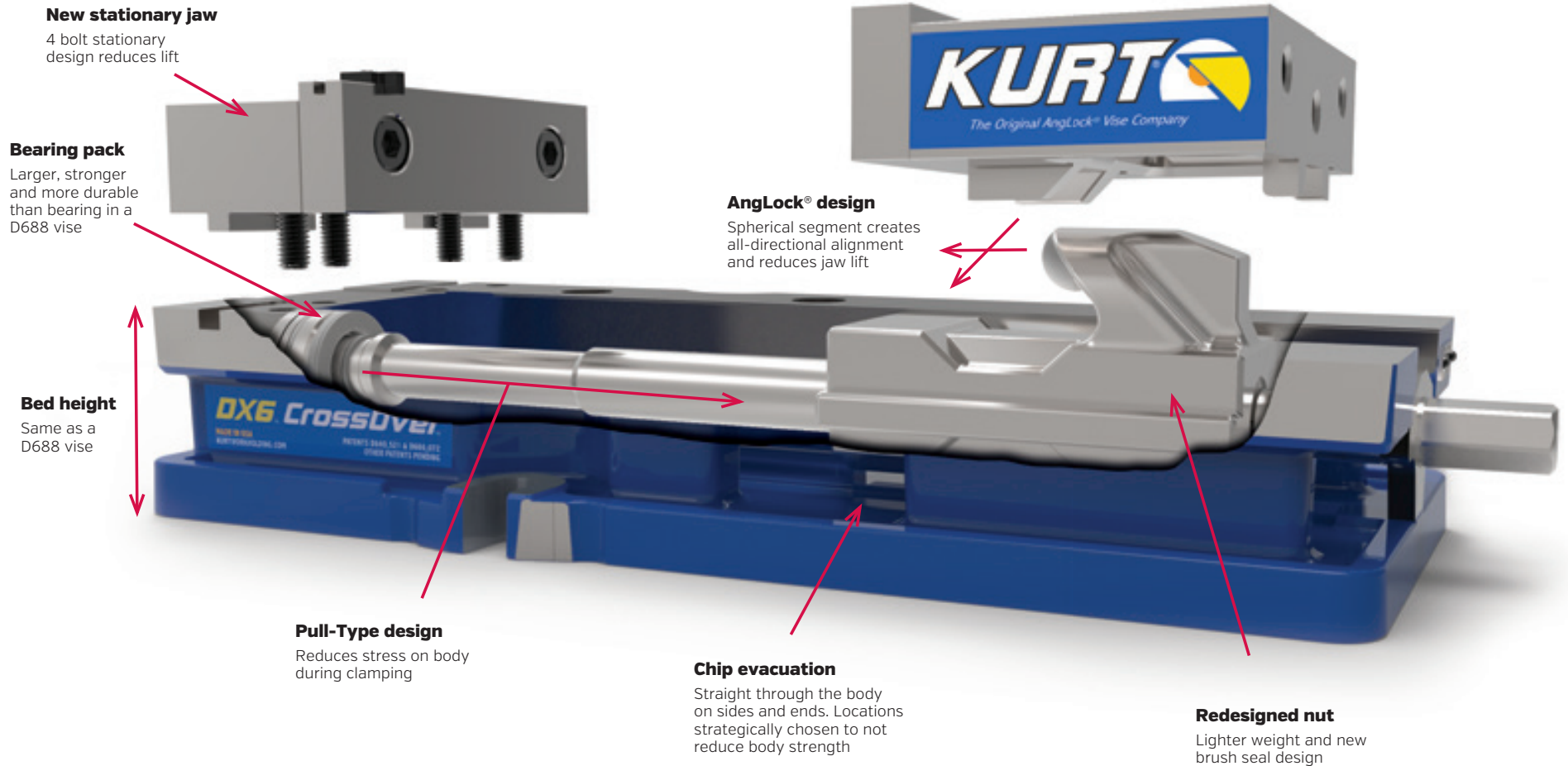

**MADE IN AMERICA**



**DX6™ CrossOver™ Features:**

1. DX6™ CrossOver™ vise is a combination of AngLock®, Pull-Type and 4 bolt stationary jaw design. When combined they create an ultra unique strategy for a better vise:  
 -*AngLock® design* reduces stress on body during clamping  
 -*Pull-type design* reduces stress on body during clamping  
 -*4 bolt design* reduces stationary jaw deflection and alleviates body stress
2. Hardened vise bed/jaw plates
3. Semi-hard steel screw
4. 80,000 psi ductile iron body, nut and movable jaw
5. Large 9" opening
6. New wider 4 bolt stationary design fastens from the top
7. Bolts & locates on 40mm, 50mm and 2" grid patterns
8. Accepts sine keys for alignment (not included)
9. Weight 65lbs.
10. Chip evacuation straight through the body
11. Screw support held in place with snap rings
12. GrooveLock® jaw plate and workstop included
13. New brush seal design makes it easier to replace
14. Includes chip guard
15. Powder coat paint is long lasting and durable
16. Matching of the bed heights or keyway to stationary jaw (additional cost)
17. Fits on D50-4-SA swivel base
18. Lifetime Iron Clad Warranty

**DX6™ CrossOver™ features comparison to D688 Vise:**

19. DX6 is a replacement vise to D688 vise
20. Larger opening (9.0" versus 8.8")
21. Same bed height as D688
22. Narrower body style than D688 and allows more vises on machine table
23. Larger, stronger, and more durable bearing pack lasts longer
24. Same distance from the keyway to stationary as D688
25. DX6 weight 65lbs. vs D688 69lbs.

**DX6™ CrossOver™ Vise Models available:**

- DX6 Manual
- DX6H Hydraulic
- DX6R Manual Reverse
- DX6HR Hydraulic Reverse

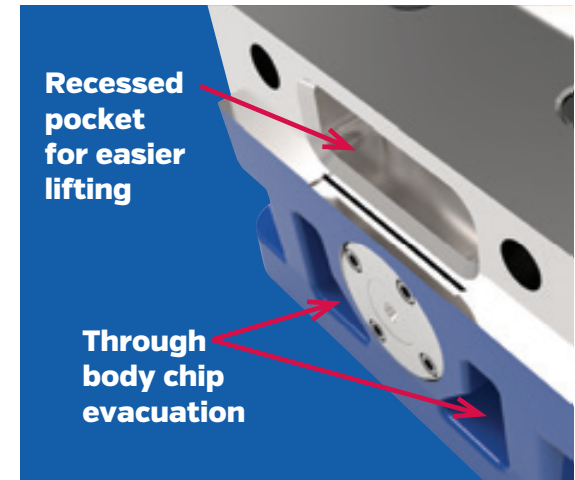
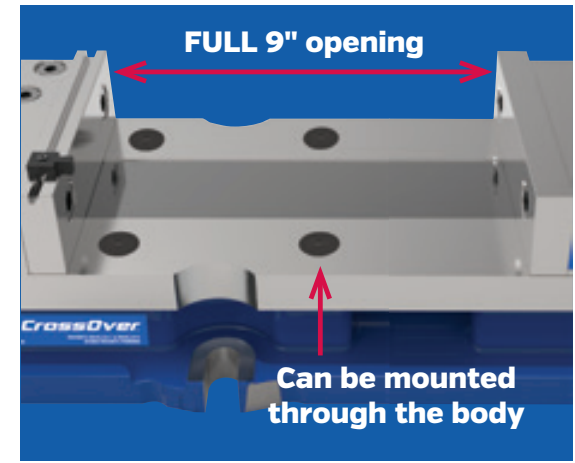

# DX6™ CrossOver™ Vise

A better vise than our own D688 in everyway we measure a vise

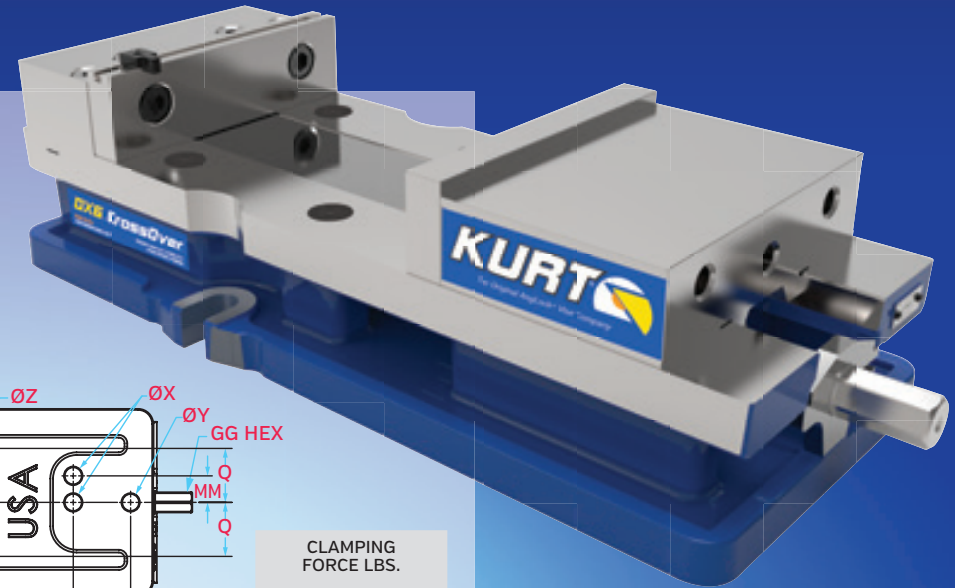

	A	B	C	D	E	F	G	H	I	J	K	L	M	N	O	P	P METRIC	Q
<b>DX6</b>	2.875	6.000	16.810	2.837	0.656	1.485	2.312	1.735	7.391	0.725	4.000	2.295	0.328	0.940	3.875	1/2-13	M12	2.000
	R	S	T	U	V	W	X	Y	Z	AA	BB	CC	DD	EE	FF	GG	HH	MM
<b>DX6</b>	2.986	80 mm	200 mm	100 mm	10.000	4.000	16 mm	0.625	0.992	9.080	12.117	13.805	16.842	2.480	3.375	3/4	1.448	25 mm

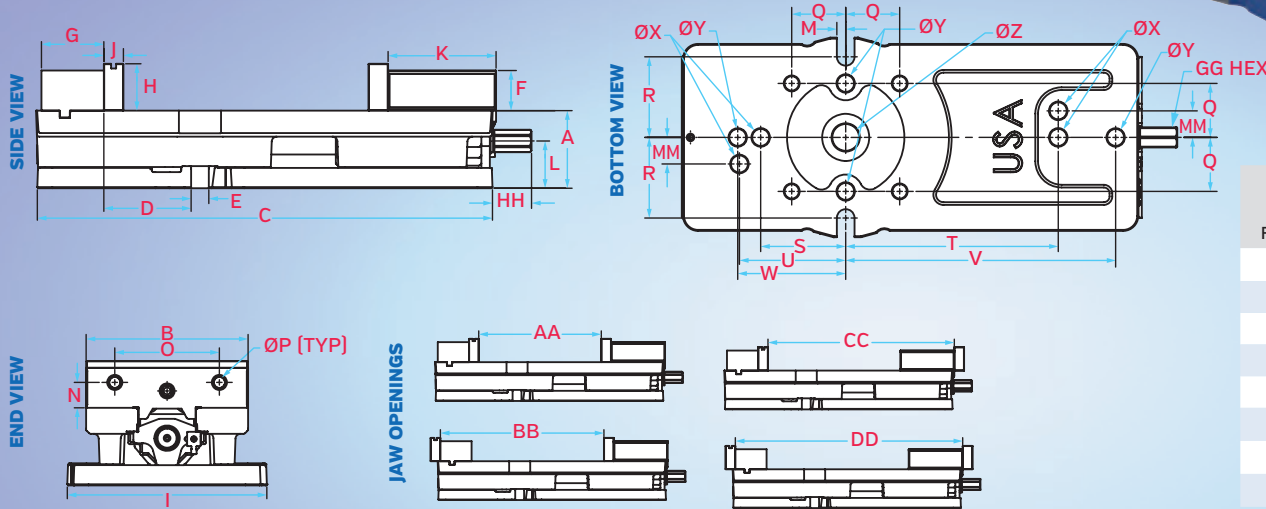

CLAMPING FORCE LBS.	
Ft. Lbs	Lbs Force
10	786
20	1,800
30	2,508
40	3,423
50	4,210
60	5,020
70	6,287
80	6,884

DX6™, CrossOver™ are trademarks of Kurt Manufacturing

AngLock®, GrooveLock®, KURT® are registered trademarks of Kurt Manufacturing

PATENTS D640,521 & D666,072 & OTHER U.S. PATENTS PENDING

**Kurt® Manufacturing**  
 Industrial Products Division  
 9445 E. River Road NW, Minneapolis, MN 55433

Phone 763.574.8309 Toll Free Phone US & Canada 1.877.226.7823  
 Fax 763.574.8313 Toll Free Fax US Only 1.877.226.7828  
 email [workholding@kurt.com](mailto:workholding@kurt.com)  
[www.kurtworkholding.com](http://www.kurtworkholding.com)

**KURT®**  
 The Original AngLock® Vise Company