

Promo

# Milling Accessories

Quality,  
Speed, &  
Performance



[sales@doriantool.com](mailto:sales@doriantool.com)

1.800.627.0266

**D** **DORIAN**  
INTERNATIONAL  
**TOOL**



**.0001" Taper-Bore Runout Tolerance**  
Means more cutting tool life and better surface finish

**Made of 8620 Alloy Steel with Case Hardness of 56-60 HRC and Core Hardness of 36-40 HRC**

*Translates into durability and rigidity*

**Tapers Ground to AT-3 Specifications or BETTER**

*Ensures precise fit with max contact surface area with machine spindle. Translates into more cutting tool life and better surface finish.*

**H5 Bore Tolerance for air-tight fit provides maximum contact surface area**

*Provides a very close tolerance fit with minimum runout between the tool holder's bore and the cutting tool. Translates into more cutting tool life and better surface finish.*

**Thru Coolant Feature**

*Thru Hole of the toolholder allows the use of Thru Coolant Tools when used with a Thru Coolant retention knob*

**Made In Italy**

**Up to 47%  
off!**

**Precision Balanced to  
12,000 RPM**

UPC#	Description	Hole Dia. (d) (in)	Gage Length (L) (in)	Body Dia (D) (in)	List Price	Promo
45011-Z25A1	CAT40 EMH-0250-2500	1/4	2.50	.88	\$103.95	<b>\$55</b>
45017-Z25A1	CAT40 EMH-0375-2500	3/8	2.50	1.00	\$103.95	<b>\$55</b>
45023-Z25A1	CAT40-EMH-0500-2500	1/2	2.50	1.25	\$103.95	<b>\$55</b>
45026-Z25A1	CAT40 EMH-0625-1750	5/8	1.75	1.75	\$103.95	<b>\$55</b>
45027-Z25A1	CAT40 EMH-0625-3000	5/8	3.00	1.50	\$103.95	<b>\$55</b>
45030-Z25A1	CAT40 EMH-0750-1750	3/4	1.75	1.75	\$103.95	<b>\$55</b>
45031-Z25A1	CAT40 EMH-0750-3000	3/4	3.00	1.75	\$103.95	<b>\$55</b>
45037-Z25A1	CAT40 EMH-1000-2000	1	2.00	1.75	\$108.57	<b>\$58</b>
45038-Z25A1	CAT40 EMH-1000-4000	1	4.00	2.00	\$121.28	<b>\$65</b>
45069-Z25A1	CAT50 EMH-0500-4000	1/2	4.00	1.25	\$190.00	<b>\$101</b>
45079-Z25A1	CAT50 EMH-0750-4000	3/4	4.00	1.75	\$190.00	<b>\$101</b>
45080-Z25A1	CAT50 EMH-0750-6000	3/4	6.00	1.75	\$231.00	<b>\$123</b>
45086-Z25A1	CAT50 EMH-1000-4000	1	4.00	2.00	\$199.24	<b>\$106</b>
45087-Z25A1	CAT50 EMH-1000-6000	1	6.00	2.00	\$259.88	<b>\$139</b>
45090-Z25A1	CAT50 EMH-1250-4000	1 1/4	4.00	2.50	\$231.00	<b>\$123</b>
45091-Z25A1	CAT50 EMH-1250-6000	1 1/4	6.00	2.50	\$277.20	<b>\$148</b>
45094-Z25A1	CAT50 EMH-1500-4500	1 1/2	4.50	2.75	\$242.55	<b>\$129</b>
45095-Z25A1	CAT50 EMH-1500-7000	1 1/2	7.0	2.75	\$277.20	<b>\$148</b>

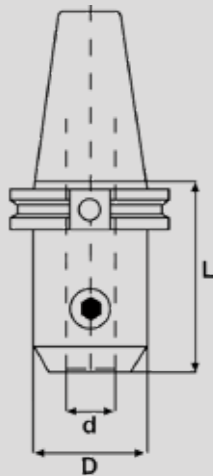

# SHELL MILL HOLDERS



**.0002" Taper-Arbor Runout Tolerance**  
*Means more cutting tool life and better surface finish.*

**Made of 8620 Alloy Steel with Case Hardness of 56-60 HRC and Core Hardness of 36-40 HRC**  
*Translates into durability and rigidity.*

**Tapers Ground to AT-3 Specifications or BETTER**  
*Ensures precise fit with max contact surface area with machine spindle. Translates into more cutting tool life and better surface finish.*

**H5 Arbor Tolerance**  
*Provides a very close tolerance fit with minimum runout between the tool holder's arbor and the cutting tool. Translates into more cutting tool life and better surface finish.*

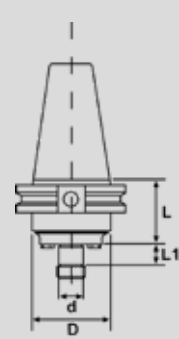

**Precision Balanced to 12,000 RPM**

**Made In Italy**

**Up to 47% off!**

UPC#	Description	Arbor Dia. (d) (in)	Arbor Length (L1) (in)	Gage Length (L) (in)	Body Dia (D) (in)	Arbor Thread (AT)(in)	Key Size (in)	List Price	Promo
45121-Z25A1	CAT40 SMH-0750-1750	3/4	.67	1.75	1.75	3/8-24	5/16	\$132.83	<b>\$71</b>
45123-Z25A1	CAT40 SMH-1000-1750	1	.67	1.75	2.25	1/2-20	3/8	\$132.83	<b>\$71</b>
45125-Z25A1	CAT40 SMH-1250-2000	1-1/4	.67	2.00	2.88	5/8-18	1/2	\$141.49	<b>\$75</b>
45127-Z25A1	CAT40 SMH-1500-2000	1-1/2	.93	2.00	3.75	3/4-16	5/8	\$150.15	<b>\$80</b>
45138-Z25A1	CAT50 SMH-0750-1750	3/4	.68	1.75	2.75	3/8-24	5/16	\$179.03	<b>\$95</b>
45142-Z25A1	CAT50 SMH-1000-1750	1	.68	1.75	2.75	1/2-20	3/8	\$179.03	<b>\$95</b>
45146-Z25A1	CAT50 SMH-1250-1750	1-1/4	.68	1.75	2.75	5/8-18	1/2	\$187.11	<b>\$100</b>
45150-Z25A1	CAT50 SMH-1500-2000	1-1/2	.94	2.00	3.75	3/4-16	5/8	\$199.82	<b>\$107</b>
45154-Z25A1	CAT50 SMH-2000-2000	2	.94	2.00	4.88	1-14	5/8	\$277.20	<b>\$148</b>

# INTEGRAL KEYLESS DRILL CHUCK HOLDERS



UPC#	Description	Tool Capacity	Gage Length (L) (in)	Body Dia. (D) (in)	List Price	Promo
45307-Z25A1	CAT40-KDCH-13	1/32-1/2	3.50	2.00	\$272.25	<b>\$145</b>
45308-Z25A1	CAT40-KDCH-16	1/8-5/8	4.50	2.25	\$306.90	<b>\$164</b>

Provides exceptionally high torque, up to three times the gripping strength of conventional drill chucks.

Replaceable chuck.

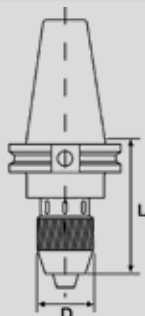

Features a corrosion-resistant surface treatment to ensure durability.

Chuck will not come off during operation.



## ER COLLET HOLDERS

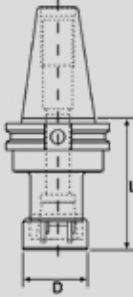

**.0001" Taper-Bore Runout Tolerance**  
Means more cutting tool life and better surface finish

**Made of 8620 Alloy Steel with Case Hardness of 56-60 HRC and Core Hardness of 36-40 HRC.**

*Translates into durability and rigidity*

**Tapers Ground to AT-3 Specifications or BETTER**

*Ensures precise fit with max contact surface area with machine spindle.  
Translates into more cutting tool life and better surface finish.*

**Thru Coolant Feature**

*Thru Hole of the toolholder allows the use of Thru Coolant Tools when used with a Thru Coolant retention knob and sealed collet.*

**Made In Italy**

**Up to  
47%  
off!**

**Precision Balanced  
to 12,000 RPM**

UPC#	Description	Series	Tool Dia. Range	Nose Dia. (D) (in)	Gage Length (L) (in)	List Price	Promo
45173-Z25A1	CAT40 ER11H-2500	ER11	.019-.275	0.63	2.50	\$118.80	<b>\$63</b>
45174-Z25A1	CAT40 ER11H-4000	ER11	.019-.275	0.63	4.00	\$149.82	<b>\$80</b>
45175-Z25A1	CAT40 ER11H-6000	ER11	.019-.275	0.63	6.00	\$232.98	<b>\$124</b>
45176-Z25A1	CAT40 ER16H-2500	ER16	.019-.406	1.26	2.50	\$118.80	<b>\$63</b>
45178-Z25A1	CAT40 ER16H-4000	ER16	.019-.406	1.26	4.00	\$149.82	<b>\$80</b>
45179-Z25A1	CAT40 ER16H-6000	ER16	.019-.406	1.26	6.00	\$203.86	<b>\$109</b>
45180-Z25A1	CAT40 ER20H-2500	ER20	.039-.511	1.38	2.50	\$118.80	<b>\$63</b>
45181-Z25A1	CAT40 ER20H-4000	ER20	.039-.511	1.38	4.00	\$149.82	<b>\$80</b>
45182-Z25A1	CAT40 ER20H-6000	ER20	.039-.511	1.38	6.00	\$203.86	<b>\$109</b>
45183-Z25A1	CAT40 ER25H-2500	ER25	.039-.629	1.65	2.50	\$118.80	<b>\$63</b>
45184-Z25A1	CAT40 ER25H-4000	ER25	.039-.629	1.65	4.00	\$149.82	<b>\$80</b>
45185-Z25A1	CAT40 ER25H-6000	ER25	.039-.629	1.65	6.00	\$203.86	<b>\$109</b>
45186-Z25A1	CAT40 ER32H-2500	ER32	.078-.787	1.97	2.50	\$133.65	<b>\$71</b>
45188-Z25A1	CAT40 ER32H-4000	ER32	.078-.787	1.97	4.00	\$168.55	<b>\$90</b>
45189-Z25A1	CAT40 ER32H-6000	ER32	.078-.787	1.97	6.00	\$203.86	<b>\$109</b>
45191-Z25A1	CAT40 ER40H-2500	ER40	.118-1.023	2.48	2.50	\$147.02	<b>\$78</b>
45193-Z25A1	CAT40 ER40H-4000	ER40	.118-1.023	2.48	4.00	\$187.44	<b>\$100</b>
45197-Z25A1	CAT50 ER16H-4120	ER16	.019-.406	1.26	4.12	\$229.27	<b>\$122</b>
45205-Z25A1	CAT50 ER25H-4000	ER25	.039-.629	1.65	4.00	\$229.27	<b>\$122</b>
45206-Z25A1	CAT50 ER25H-6000	ER25	.039-.629	1.65	6.00	\$277.20	<b>\$148</b>
45208-Z25A1	CAT50 ER32H-4000	ER32	.078-.787	1.97	4.00	\$229.27	<b>\$122</b>
45209-Z25A1	CAT50 ER32H-6000	ER32	.078-.787	1.97	6.00	\$277.20	<b>\$148</b>
45210-Z25A1	CAT50 ER32H-8000	ER32	.078-.787	1.97	8.00	\$317.63	<b>\$169</b>

### ER Collet Nuts

UPC#	Description	Series	Thread	Height (in)	Body Dia. (in)	List Price	Promo
49773-Z25A1	ER11NTM16	ER11	M13 x .75	.47	.63	\$26.40	<b>\$14</b>
49780-Z25A1	ER16NTS32	ER16	M22 X 1.5	.67	1.26	\$26.40	<b>\$14</b>
49781-Z25A1	ER20NTS35	ER20	M25 X 1.5	.75	1.38	\$26.40	<b>\$14</b>
49782-Z25A1	ER25NTS42	ER25	M32 X 1.5	.79	1.65	\$26.40	<b>\$14</b>
49783-Z25A1	ER32NTS50	ER32	M40 X 1.5	.89	1.97	\$26.40	<b>\$14</b>
49784-Z25A1	ER40NTS63	ER40	M50 X 1.5	1.00	2.48	\$26.40	<b>\$14</b>

### ER Collet Wrenches

UPC#	Description	Series	Wrench Type	List Price	Promo
49987-Z25A1	ER11MNWR	ER11	ER Mini	\$36.30	<b>\$19</b>
49994-Z25A1	ER16STWR	ER16	ER Standard	\$39.60	<b>\$21</b>
49995-Z25A1	ER20STWR	ER20	ER Standard	\$39.60	<b>\$21</b>
49996-Z25A1	ER25STWR	ER25	ER Standard	\$39.60	<b>\$21</b>
49997-Z25A1	ER32STWR	ER32	ER Standard	\$39.60	<b>\$21</b>
49998-Z25A1	ER40STWR	ER40	ER Standard	\$39.60	<b>\$21</b>

# RETENTION KNOBS

Precision Ground

Up to  
47%  
off!

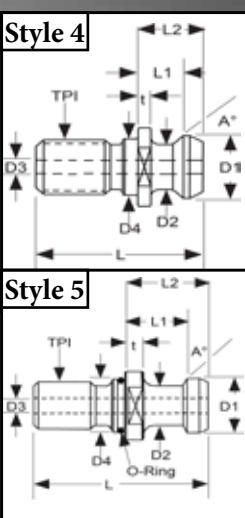
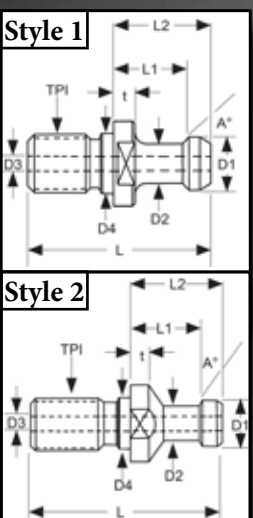

UPC #	CAT 40 Description	Machines Used on	Thru Coolant	Style	Threads TPI	A Angle	D1 Knob Dia.	D2 Neck Dia.	D3 Hole Dia.	D4 Pilot Dia.	L OAL	Shoulder			List Price	Promo
												L1	t	L2		
47287-Z25A1	RKCT40-4-0004	Mazak, Fadal, DMG, Hurco	N/A	4	5/8-11	45°	0.740	0.490	NA	0.636	1.620	0.440	0.120	0.640	\$16.94	\$9
47286-Z25A1	RKCT40-4-0003-C	Fadal, DMG, Hurco	Coolant	4	5/8-11	45°	0.740	0.490	0.281	0.636	1.620	0.440	0.120	0.640	\$16.94	\$9
47831-Z25A1	RKCT40-1-0103	Mori Seiki, OKK, Kira	N/A	1	5/8-11	90°	0.589	0.392	NA	0.636	2.250	0.988	0.234	1.264	\$18.17	\$9.70
47305-Z25A1	RKCT40-1-0022	Bridgeport, Leadwell	N/A	1	5/8-11	45°	0.589	0.392	NA	0.636	2.250	0.988	0.124	1.264	\$18.17	\$9.70
47304-Z25A1	RKCT40-1-0021	Haas, Chevalier, Feeler, Fryer, Johnford	N/A	1	5/8-11	45°	0.589	0.392	NA	0.636	2.250	0.988	0.234	1.264	\$18.17	\$9.70
47313-Z25A1	RKCT40-1-0030-C	Haas, Chevalier, Feeler, Fryer, Johnford	Coolant	1	5/8-11	45°	0.589	0.392	0.200	0.636	2.250	0.988	0.234	1.264	\$18.17	\$9.70
47386-Z25A1	RKCT40-1-0121	Makino, Mitsubishi, Enshu, Hitachi, Kira, Okuma, Milltronics	N/A	1	5/8-11	60°	0.589	0.392	NA	0.636	2.250	0.988	0.234	1.264	\$18.17	\$9.70
47288-Z25A1	RKCT40-4-0005-C	Mazak, Fadal, DMG, Hurco	Coolant	4	5/8-11	45°	0.740	0.490	0.280	0.641	1.620	0.440	0.120	0.640	\$16.94	\$9
47359-Z25A1	RKCT40-5-0076-C	Makino	Coolant	5	5/8-11	15°	0.746	0.549	0.236	0.641	2.008	0.792	0.276	1.028	\$18.17	\$9.70
47387-Z25A1	RKCT40-3-0122-C	Mori Seiki	Coolant	2	5/8-11	15°	0.747	0.548	0.236	0.641	2.004	0.787	0.157	1.024	\$18.17	\$9.70
47343-Z25A1	RKCT40-2-0060-C	Kitamura, Doosan, Hyundai, Kia	Coolant	2	5/8-11	15°	0.747	0.549	0.281	0.641	2.004	0.787	0.157	1.024	\$18.17	\$9.70
UPC #	CAT 50 Description	Machines Used on	Thru Coolant	Style	Threads TPI	A Angle	D1 Knob Dia.	D2 Neck Dia.	D3 Hole Dia.	D4 Pilot Dia.	L OAL	Shoulder			List Price	Promo
												L1	t	L2		
47292-Z25A1	RKCT50-4-0010	Mazak, DMG, G&L, Hurco, Fadal, Walter Grinders	N/A	4	1-8	45°	1.140	0.820	NA	1.026	2.575	0.700	0.200	1.000	\$25.26	\$13.50
47291-Z25A1	RKCT50-4-0009-C	Mazak, DMG, G&L, Hurco, Fadal	Coolant	4	1-8	45°	1.140	0.820	0.468	1.026	2.575	0.700	0.200	1.000	\$25.26	\$13.50
47320-Z25A1	RKCT50-1-0037-C	OKK	Coolant	1	1-8	90°	0.903	0.668	0.250	1.026	3.350	1.384	0.392	1.778	\$26.80	\$14.30
47319-Z25A1	RKCT50-1-0036-C	Okuma, Hitachi, SNK, Toshiba	Coolant	1	1-8	60°	0.903	0.668	0.335	1.026	3.355	1.384	0.392	1.778	\$26.80	\$14.30
47306-Z25A1	RKCT50-1-0023	Okuma, Hitachi, SNK, Toshiba	N/A	1	1-8	60°	0.903	0.668	NA	1.026	3.355	1.384	0.392	1.778	\$26.80	\$14.30
47308-Z25A1	RKCT50-1-0025-C	Haas, Milltronics, Viper, Enshu, Awea	Coolant	1	1-8	45°	0.903	0.668	0.312	1.026	3.355	1.384	0.392	1.778	\$26.80	\$14.30
47309-Z25A1	RKCT50-1-0026	Haas, Milltronics, Viper, Enshu, Awea	N/A	1	1-8	45°	0.903	0.668	NA	1.026	3.355	1.384	0.392	1.778	\$26.80	\$14.30
47317-Z25A1	RKCT50-1-0034-C	Doosan, Hyundai, Kia	Coolant	1	1-8	45°	0.903	0.668	0.390	1.026	3.355	1.384	0.392	1.778	\$26.80	\$14.30
47388-Z25A1	RKCT50-1-0123-C	Toyoda	Coolant	1	1-8	45°	0.903	0.668	0.236	1.030	3.353	1.384	0.400	1.778	\$26.80	\$14.30
47389-Z25A1	RKCT50-1-0124	Mori Seiki, OKK, Yang	N/A	1	1-8	90°	0.903	0.668	NA	1.026	3.350	1.384	0.392	1.778	\$25.26	\$13.50
47318-Z25A1	RKCT50-1-0035-C	Makino	Coolant	1	1-8	45°	0.903	0.668	0.236	1.026	3.353	1.384	0.392	1.778	\$26.80	\$14.30



## 16 SLITS FOR UNIFORM GRIPPING



**100% Inspection:**  
Each and every collet is inspected to be precise within .0002" or better prior to shipping.

**Maximum Contact Surface Area:**  
Each Dorian ER Collet features 16 full length slits (instead of competition's 8), enabling the collet to collapse uniformly to provide a concentric and full 360° gripping surface.

**Material:**  
Premium Grade Special Alloy Steel with high a modulus of elasticity. Combined with the 16-slit design, this material provides full surface contact on the tool when collapsed.

**Inch and Metric Sizes:**  
Choice of inch and metric sizes optimizes contact surface area for ultra high precision applications.

**ULTRA-PRECISION  
.0002" TIR**



### Ultra-Precision ER20 Collets

### Ultra-Precision ER11 Collets

UPC#	Description	Holding Range (in)
46236-Z25A1	ER11-STIMC-10	0.02 - 0.039
46237-Z25A1	ER11-STIMC-15	0.039 - 0.059
46238-Z25A1	ER11-STIMC-20	0.059 - 0.079
46249-Z25A1	ER11-STIMC-0937	0.074 - 0.094
46239-Z25A1	ER11-STIMC-25	0.079 - 0.098
46240-Z25A1	ER11-STIMC-30	0.098 - 0.118
46250-Z25A1	ER11-STIMC-0125	0.105 - 0.125
46241-Z25A1	ER11-STIMC-35	0.118 - 0.138
46242-Z25A1	ER11-STIMC-40	0.138 - 0.157
46243-Z25A1	ER11-STIMC-45	0.157 - 0.177
46251-Z25A1	ER11-STIMC-0187	0.168 - 0.188
46244-Z25A1	ER11-STIMC-50	0.177 - 0.197
46245-Z25A1	ER11-STIMC-55	0.197 - 0.217
46246-Z25A1	ER11-STIMC-60	0.217 - 0.236
46252-Z25A1	ER11-STIMC-0250	0.23 - 0.25
46247-Z25A1	ER11-STIMC-65	0.236 - 0.256
46248-Z25A1	ER11-STIMC-70	0.256 - 0.276

List Price: \$19.64

**Promo: \$10.47**

### Ultra-Precision ER16 Collets

UPC#	Description	Holding Range (in)
46290-Z25A1	ER16-STIMC-10	0.02 - 0.039
46288-Z25A1	ER16-STIMC-15	0.039 - 0.059
46291-Z25A1	ER16-STIMC-20	0.059 - 0.079
46275-Z25A1	ER16-STIMC-0937	0.074 - 0.094
46289-Z25A1	ER16-STIMC-25	0.059 - 0.098
46292-Z25A1	ER16-STIMC-30	0.079 - 0.118
46276-Z25A1	ER16-STIMC-0125	0.087 - 0.125
46293-Z25A1	ER16-STIMC-40	0.118 - 0.157
46278-Z25A1	ER16-STIMC-0187	0.15 - 0.188
46294-Z25A1	ER16-STIMC-50	0.157 - 0.197
46295-Z25A1	ER16-STIMC-60	0.197 - 0.236
46280-Z25A1	ER16-STIMC-0250	0.213 - 0.25
46296-Z25A1	ER16-STIMC-70	0.236 - 0.276
46297-Z25A1	ER16-STIMC-80	0.276 - 0.315
46298-Z25A1	ER16-STIMC-90	0.315 - 0.354
46284-Z25A1	ER16-STIMC-0375	0.335 - 0.375
46299-Z25A1	ER16-STIMC-100	0.354 - 0.394

List Price: \$17.53

**Promo: \$9.35**

UPC#	Description	Holding Range (in)
46353-Z25A1	ER20-STIMC-10	0.02 - 0.039
46354-Z25A1	ER20-STIMC-15	0.039 - 0.059
46355-Z25A1	ER20-STIMC-20	0.059 - 0.079
46356-Z25A1	ER20-STIMC-30	0.079 - 0.118
46386-Z25A1	ER20-STIMC-0937	0.075 - 0.094
46387-Z25A1	ER20-STIMC-0125	0.087 - 0.125
46358-Z25A1	ER20-STIMC-40	0.118 - 0.157
46388-Z25A1	ER20-STIMC-0187	0.15 - 0.188
46359-Z25A1	ER20-STIMC-50	0.157 - 0.197
46360-Z25A1	ER20-STIMC-60	0.197 - 0.236
46389-Z25A1	ER20-STIMC-0250	0.213 - 0.25
46361-Z25A1	ER20-STIMC-70	0.236 - 0.276
46362-Z25A1	ER20-STIMC-80	0.276 - 0.315
46363-Z25A1	ER20-STIMC-90	0.315 - 0.354
46390-Z25A1	ER20-STIMC-0375	0.335 - 0.375
46364-Z25A1	ER20-STIMC-100	0.354 - 0.394
46365-Z25A1	ER20-STIMC-110	0.394 - 0.433
46367-Z25A1	ER20-STIMC-120	0.433 - 0.472
46391-Z25A1	ER20-STIMC-0500	0.461 - 0.5
46368-Z25A1	ER20-STIMC-130	0.472 - 0.512

List Price: \$17.53

**Promo: \$9.35**

# ULTRA-PRECISION ER COLLET SETS



Ultra-Precision ER40 Collets

UPC#	Collet Series	Description	Total Pcs.	Included in Set:	List Price	Promo
46768-Z25A1	ER11	ER11-MCS-13C	13	1, 1.5, 2, 2.5, 3, 3.5, 4, 4.5, 5, 5.5, 6, 6.5, 7mm	\$264.14	<b>\$141</b>
46769-Z25A1	ER16	ER16-MCS-10C	10	1, 2, 3, 4, 5, 6, 7, 8, 9, 10mm	\$184.66	<b>\$98</b>
46770-Z25A1	ER20	ER20-MCS-12C	12	2, 3, 4, 5, 6, 7, 8, 9, 10, 11, 12, 13mm	\$219.73	<b>\$117</b>
46771-Z25A1	ER25	ER25-MCS-15C	15	2, 3, 4, 5, 6, 7, 8, 9, 10, 11, 12, 13, 14, 15, 16mm	\$296.86	<b>\$158</b>
46772-Z25A1	ER32	ER32-MCS-18C	18	3, 4, 5, 6, 7, 8, 9, 10, 11, 12, 13, 14, 15, 16, 17, 18, 19, 20mm	\$374.00	<b>\$199</b>
46773-Z25A1	ER40	ER40-MCS-23C	23	4, 5, 6, 7, 8, 9, 10, 11, 12, 13, 14, 15, 16, 17, 18, 19, 20, 21, 22, 23, 24, 25, 26mm	\$561.00	<b>\$299</b>

Up to  
**47%**  
off!

## Ultra-Precision ER25 Collets

UPC#	Description	Holding Range (in)
46428-Z25A1	ER25-STIMC-10	0.02 - 0.039
46429-Z25A1	ER25-STIMC-15	0.039 - 0.059
46430-Z25A1	ER25-STIMC-20	0.059 - 0.079
46499-Z25A1	ER25-STIMC-0937	0.075 - 0.094
46431-Z25A1	ER25-STIMC-30	0.079 - 0.118
46500-Z25A1	ER25-STIMC-0125	0.086 - 0.125
46433-Z25A1	ER25-STIMC-40	0.118 - 0.157
46501-Z25A1	ER25-STIMC-0187	0.148 - 0.188
46434-Z25A1	ER25-STIMC-50	0.157 - 0.197
46435-Z25A1	ER25-STIMC-60	0.197 - 0.236
46502-Z25A1	ER25-STIMC-0250	0.211 - 0.25
46436-Z25A1	ER25-STIMC-70	0.236 - 0.276
46437-Z25A1	ER25-STIMC-80	0.276 - 0.315
46438-Z25A1	ER25-STIMC-90	0.315 - 0.354
46503-Z25A1	ER25-STIMC-0375	0.336 - 0.375
46439-Z25A1	ER25-STIMC-100	0.354 - 0.394
46440-Z25A1	ER25-STIMC-110	0.394 - 0.433
46442-Z25A1	ER25-STIMC-120	0.433 - 0.472
46517-Z25A1	ER25-STIMC-0500	0.461 - 0.5
46443-Z25A1	ER25-STIMC-130	0.472 - 0.512
46444-Z25A1	ER25-STIMC-140	0.512 - 0.551
46445-Z25A1	ER25-STIMC-150	0.551 - 0.591
46518-Z25A1	ER25-STIMC-0625	0.586 - 0.625
46446-Z25A1	ER25-STIMC-160	0.591 - 0.63

List Price: \$18.70

Promo: **\$9.97**

## Ultra-Precision ER32 Collets

UPC#	Description	Holding Range (in)
46521-Z25A1	ER32-STIMC-20	0.059 - 0.079
46543-Z25A1	ER32-STIMC-0937	0.075 - 0.094
46522-Z25A1	ER32-STIMC-30	0.079 - 0.118
46544-Z25A1	ER32-STIMC-0125	0.086 - 0.125
46524-Z25A1	ER32-STIMC-40	0.118 - 0.157
46545-Z25A1	ER32-STIMC-0187	0.148 - 0.188
46525-Z25A1	ER32-STIMC-50	0.157 - 0.197
46526-Z25A1	ER32-STIMC-60	0.197 - 0.236
46546-Z25A1	ER32-STIMC-0250	0.211 - 0.25
46527-Z25A1	ER32-STIMC-70	0.236 - 0.276
46528-Z25A1	ER32-STIMC-80	0.276 - 0.315
46529-Z25A1	ER32-STIMC-90	0.315 - 0.354
46547-Z25A1	ER32-STIMC-0375	0.336 - 0.375
46530-Z25A1	ER32-STIMC-100	0.354 - 0.394
46531-Z25A1	ER32-STIMC-110	0.394 - 0.433
46533-Z25A1	ER32-STIMC-120	0.433 - 0.472
46569-Z25A1	ER32-STIMC-0500	0.461 - 0.5
46534-Z25A1	ER32-STIMC-130	0.472 - 0.512
46535-Z25A1	ER32-STIMC-140	0.512 - 0.551
46536-Z25A1	ER32-STIMC-150	0.551 - 0.591
46570-Z25A1	ER32-STIMC-0625	0.586 - 0.625
46537-Z25A1	ER32-STIMC-160	0.591 - 0.63
46538-Z25A1	ER32-STIMC-170	0.63 - 0.669
46539-Z25A1	ER32-STIMC-180	0.669 - 0.709
46540-Z25A1	ER32-STIMC-190	0.709 - 0.748
46571-Z25A1	ER32-STIMC-0750	0.713 - 0.75
46542-Z25A1	ER32-STIMC-200	0.748 - 0.787

List Price: \$19.64

Promo: **\$10.47**

UPC#	Description	Holding Range (in)
46623-Z25A1	ER40-STIMC-30	0.079 - 0.118
46649-Z25A1	ER40-STIMC-0125	0.087 - 0.125
46624-Z25A1	ER40-STIMC-40	0.118 - 0.157
46650-Z25A1	ER40-STIMC-0187	0.15 - 0.188
46625-Z25A1	ER40-STIMC-50	0.157 - 0.197
46626-Z25A1	ER40-STIMC-60	0.197 - 0.236
46651-Z25A1	ER40-STIMC-0250	0.213 - 0.25
46627-Z25A1	ER40-STIMC-70	0.236 - 0.276
46628-Z25A1	ER40-STIMC-80	0.276 - 0.315
46629-Z25A1	ER40-STIMC-90	0.315 - 0.354
46652-Z25A1	ER40-STIMC-0375	0.335 - 0.375
46630-Z25A1	ER40-STIMC-100	0.354 - 0.394
46631-Z25A1	ER40-STIMC-110	0.394 - 0.433
46633-Z25A1	ER40-STIMC-120	0.433 - 0.472
46653-Z25A1	ER40-STIMC-0500	0.461 - 0.5
46634-Z25A1	ER40-STIMC-130	0.472 - 0.512
46635-Z25A1	ER40-STIMC-140	0.512 - 0.551
46636-Z25A1	ER40-STIMC-150	0.551 - 0.591
46683-Z25A1	ER40-STIMC-0625	0.587 - 0.625
46637-Z25A1	ER40-STIMC-160	0.591 - 0.63
46638-Z25A1	ER40-STIMC-170	0.63 - 0.669
46639-Z25A1	ER40-STIMC-180	0.669 - 0.709
46640-Z25A1	ER40-STIMC-190	0.709 - 0.748
46642-Z25A1	ER40-STIMC-200	0.748 - 0.787
46686-Z25A1	ER40-STIMC-0750	0.713 - 0.75
46643-Z25A1	ER40-STIMC-210	0.787 - 0.827
46644-Z25A1	ER40-STIMC-220	0.827 - 0.866
46684-Z25A1	ER40-STIMC-0875	0.835 - 0.875
46645-Z25A1	ER40-STIMC-230	0.866 - 0.906
46646-Z25A1	ER40-STIMC-240	0.906 - 0.945
46647-Z25A1	ER40-STIMC-250	0.945 - 0.984
46685-Z25A1	ER40-STIMC-1000	0.961 - 1
46648-Z25A1	ER40-STIMC-260	0.984 - 1.024

List Price: \$23.38

Promo: **\$12.47**

The **Quik-SET Tool Presetter** is a precision instrument designed for speed and simplicity in manufacturing environments or tool cribs. It has been carefully designed to meet the needs of CNC machinists. Its portability and ruggedness make it the best presetter for small to medium machine shops.

The pre-loaded "Recirculating Ball Bearing Cage Over Precision Ground Guide" in the X-axis allows for accurate and smooth positioning to measure tool diameters, while the Z-axis can be locked to preset or re-set tool lengths quickly and precisely.

UPC #	42001	42030	42032	42034
<b>Quik-SET Model</b>	Quik-SET- Z300	Quik-SET- Z400	Quik-SET- XM	Quik-SET- Z600
<b>Price</b>	<b>\$3,375.83</b>	<b>\$4,899.51</b>	<b>\$5,397</b>	<b>\$7,236.60</b>
<b>Accuracy</b>	±.0005	±.0005	±.0005	±.0005
<b>Height Capacity (Z)</b>	11.8 in	15.8 in	11.8 in	23.6 in
<b>Diameter Capacity (X)</b>	10.0 in	10.0 in	15.8 in	23.6 in
<b>Measuring Method</b>	Contact Probe			
<b>Power Input</b>	AA Batteries			
<b>Warranty</b>	One Year			
<b>Each Presetter Supplied Standard with CAT/ISO/BT-40 Tool Sleeve</b>				

- Reduces setup time
- Excellent Precision and Repeatability
- Best Technology & Workmanship at the Lowest Price in the Industry
- Built for Shop Environment
- Made In Italy

- Precision**
- Resolution .0005in
  - Accuracy ± .0005in
  - Repeatability .0005in
  - Axis Squareness .0002in TIR

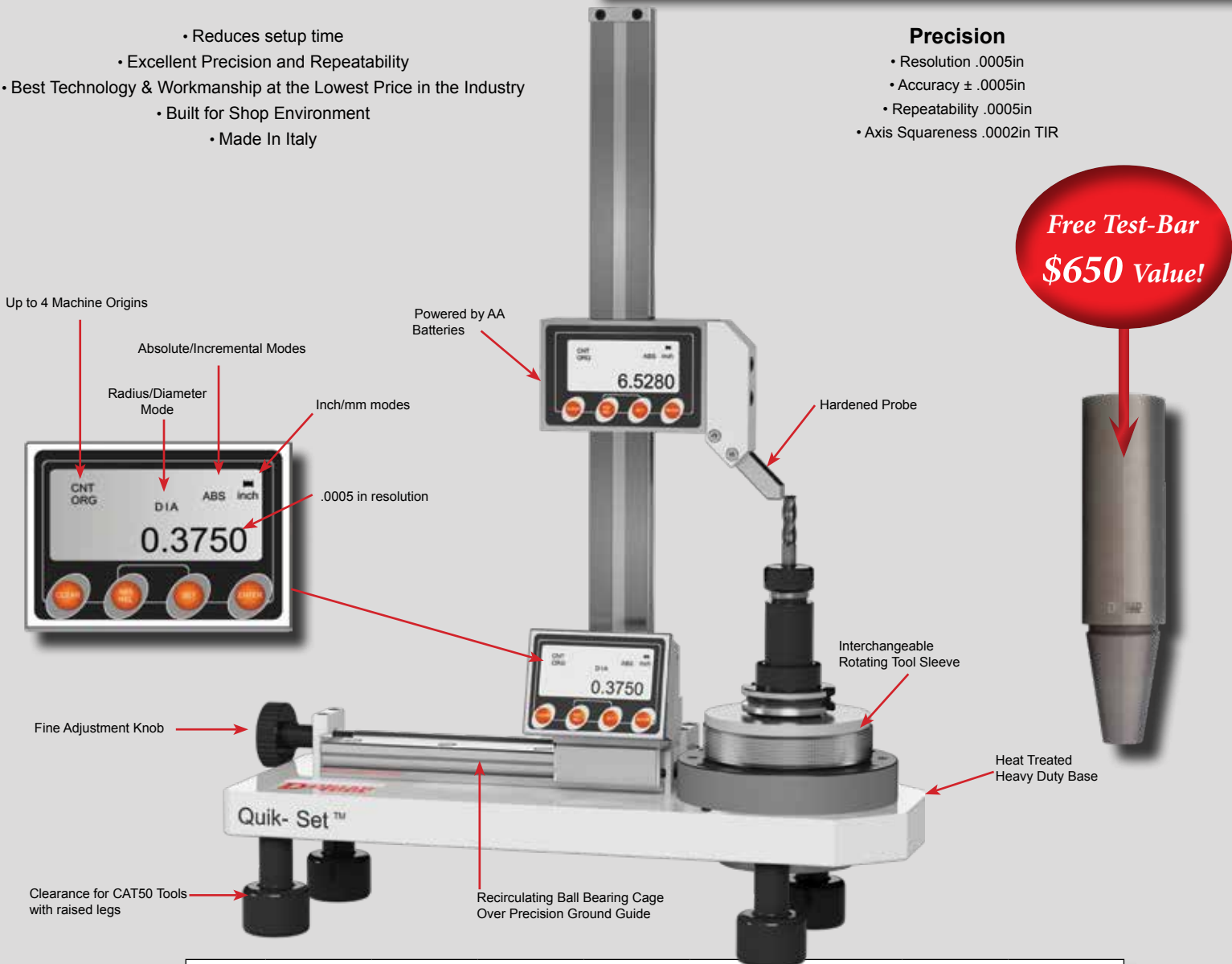

Quik-SET Optional Tool Sleeves								
Style	ISO-20	ISO/BT-30	CAT/ISO/BT-40	ISO/CAT/BT-50	HSK-40A/50F	HSK-50A/63F	HSK63A-63C	HSK-100A
<b>UPC #</b>	42073	42066	42068	42070	42076	42077	42078	42080
<b>Price</b>	<b>\$584.85</b>	<b>\$584.85</b>	<b>\$584.85</b>	<b>\$584.85</b>	<b>\$584.85</b>	<b>\$584.85</b>	<b>\$584.85</b>	<b>\$1223.25</b>



# SMART TOOL-SETTER TIGHTENING FIXTURES



Rotate the handle to lock the tool positively.

Up to 20% off!

Pull the Knob to unlock the Tool-Setter and rotate to position. Release the knob to lock in place.

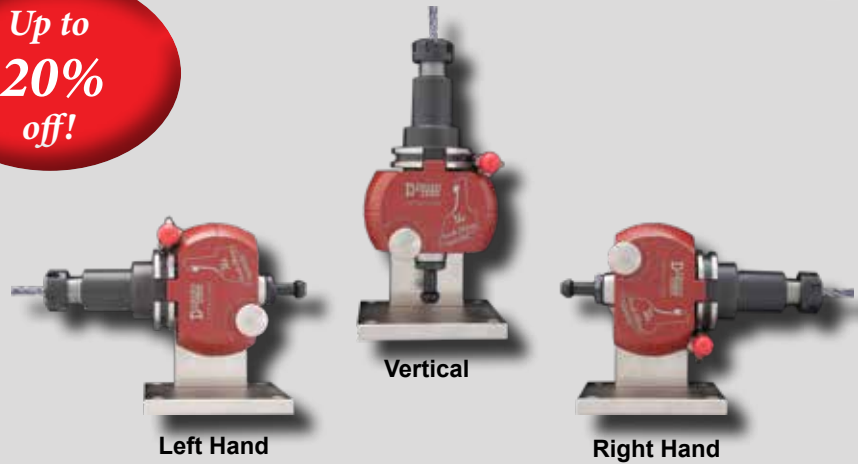

Left Hand

Vertical

Right Hand

UPC #	Description	Tool Size	List Price	Promo
36000-Z25A1	DSTSCH-030	BT-30	411.76	<b>\$329</b>
36001-Z25A1	DSTSCH-040	BT-40 CAT-40	411.76	<b>\$329</b>
36002-Z25A1	DSTSCH-050	BT-50 CAT-50	491.66	<b>\$393</b>
36003-Z25A1	DSTSHSK-063	HSK-063	558.70	<b>\$447</b>
36004-Z25A1	DSTSHSK-100	HSK-100	593.61	<b>\$475</b>

## Toolholder Taper Protected From Chips & Scratches

- Multi-Functional
- Quick Lock & Setting
- Multi-Position Setting
- Heavy Duty Construction
- Teflon Based Xylan Coating
- Precise Quality & Workmanship
- Holds CAT, BT or HSK Toolholders

### Mounting

Mounting Holes



Mount the Smart Tool-Setter on a solid workbench. Use the 4 holes provided on the base to bolt down the Smart Tool-Setter.

### Holder Loading



Put holder in while locking knob is in unlocked position. Rotate locking knob to locked position to lock holder on the V-groove located on the diameter of the holder. Locking knob positively locks the tool in and does not allow tool to come out of place.

### Application

The Smart Tool-Setter's precise and heavy duty construction make the tool-setter very rigid and able to endure extreme forces without causing any damage to tools or the Smart Tool-Setter. The multi-functioning and positioning of the Smart Tool-Setter allow the operator to switch quickly and easily from one operation to another without loss of time.

#### Small Tool Change



Endmills can be easily, quickly, and precisely set with the Smart Tool-Setter.

#### Large Tool Change

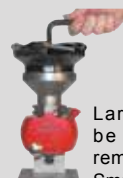

Large tools can be mounted or removed with the Smart Tool-Setter.

### Positioning



Vertical

Horizontal Left Hand

Horizontal Right Hand

Pull the indexing knob to unlock, turn into a new position, and release the indexing knob to lock.

#### Pull Stud Change



Pull Studs can be quickly and easily changed using the Smart Tool-Setter.

with Interchangeable Modular Taper Holders

## ER25 Series Collet System

- Capable of machining in two axial positioning angles
- Automatic tool change capability\*
- Made In Italy

### Interchangeable Modular Taper Holders

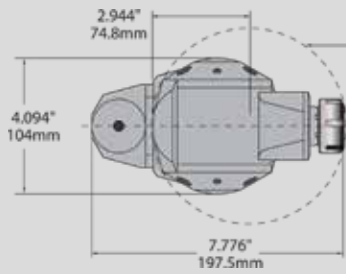
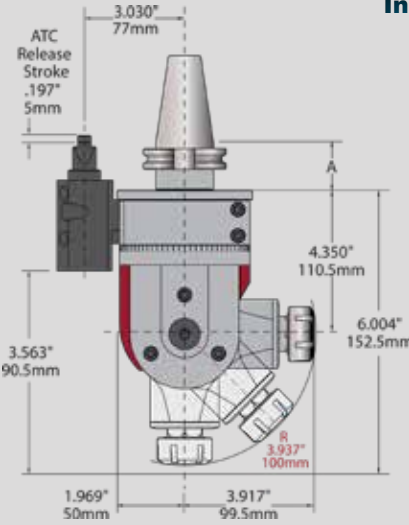
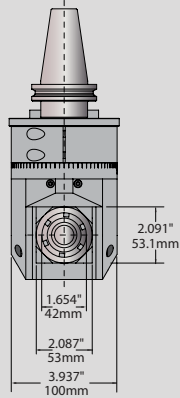
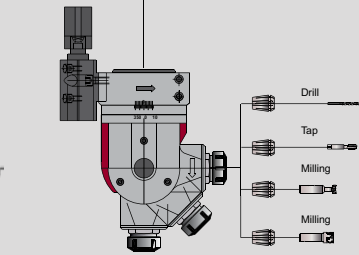

Min. Bore Size ØE  
Ø5.984\"/>

Up to  
**10%**  
off!

## ER32 Series Collet System

- Capable of machining in two axial positioning angles
- Automatic tool change capability\*
- Made In Italy

### Interchangeable Modular Taper Holders

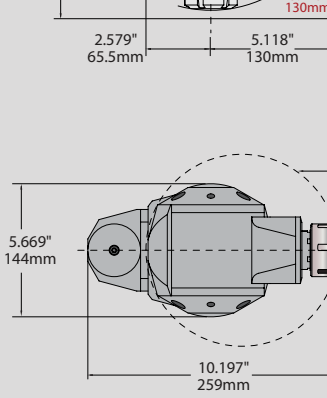
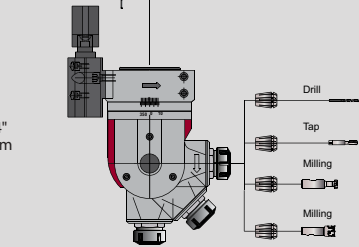

Min. Bore Size ØB  
Ø7.756\"/>

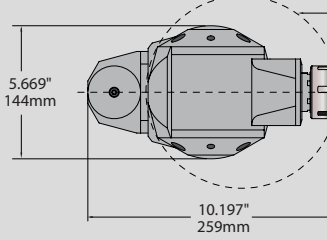
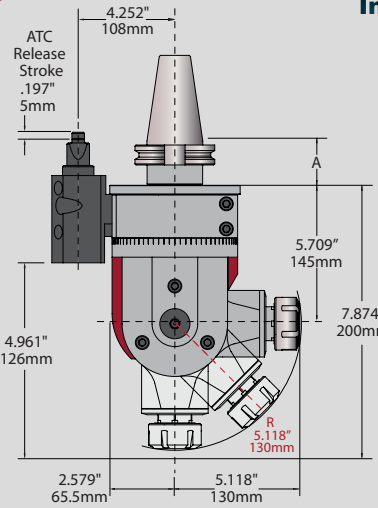

	UPC #	Description	Shank Style	Torque lb.ft	Driving Ratio	Max RPM	A Gage Line	Collet Size	Max Tool Cap. Dia.	Max. Tap Size	*Max Slotting Cutter I.D.	**Weight	List Price	Promo
ER25	45951-Z20A2	PLCNC-AAH-ER25-40DIN69871	ISO40-DIN69871	11	1 to 1	4000	1.378	ER25	0.625	0.625	1.250	14.3	\$7,046.05	<b>\$6,340</b>
	45952-Z20A2	PLCNC-AAH-ER25-BT40	BT40				1.457							
	45953-Z20A2	PLCNC-AAH-ER25-CAT40	CAT40				1.378							
	45955-Z20A2	PLCNC-AAH-ER25-50DIN69871	ISO50-DIN69871				1.457							
	45956-Z20A2	PLCNC-AAH-ER25-BT50	BT50				2.047							
	45957-Z20A2	PLCNC-AAH-ER25-CAT50	CAT50				1.457							
	UPC #	Description	Shank Style	Torque lb.ft	Driving Ratio	Max RPM	A Gage Line	Collet Size	Max. Tool Cap. Dia.	Max. Tap Size	*Max Slotting Cutter I.D.	**Weight	List Price	Promo
ER32	45941-Z20A2	PLCNC-AAH-ER32-40DIN69871	ISO40-DIN69871	29.5	1 to 1	3500	1.378	ER32	0.750	0.812	1.500	46.2	\$10,214.52	<b>\$9,190</b>
	45942-Z20A2	PLCNC-AAH-ER32-BT40	BT40				1.457							
	45943-Z20A2	PLCNC-AAH-ER32-CAT40	CAT40				1.378							
	45961-Z20A2	PLCNC-AAH-ER32-50DIN69871	ISO50-DIN69871				1.457							
	45962-Z20A2	PLCNC-AAH-ER32-BT50	BT50				2.047							
	45963-Z20A2	PLCNC-AAH-ER32-CAT50	CAT50				1.457							

\*check the max tool size and weight capacity of your machine

# RIGHT ANGLE HEADS

with Interchangeable Modular Taper Holders



## ER16 Series Collet System

- Fixed 90° angle head with 0- 360° circular rotation
- Automatic tool change capability\*
- Made In Italy

Up to  
**10% off!**

## ER25 Series Collet System



- Fixed 90° angle head with 0- 360° circular rotation
- Automatic tool change capability\*
- Made In Italy

### Interchangeable Modular Taper Holders

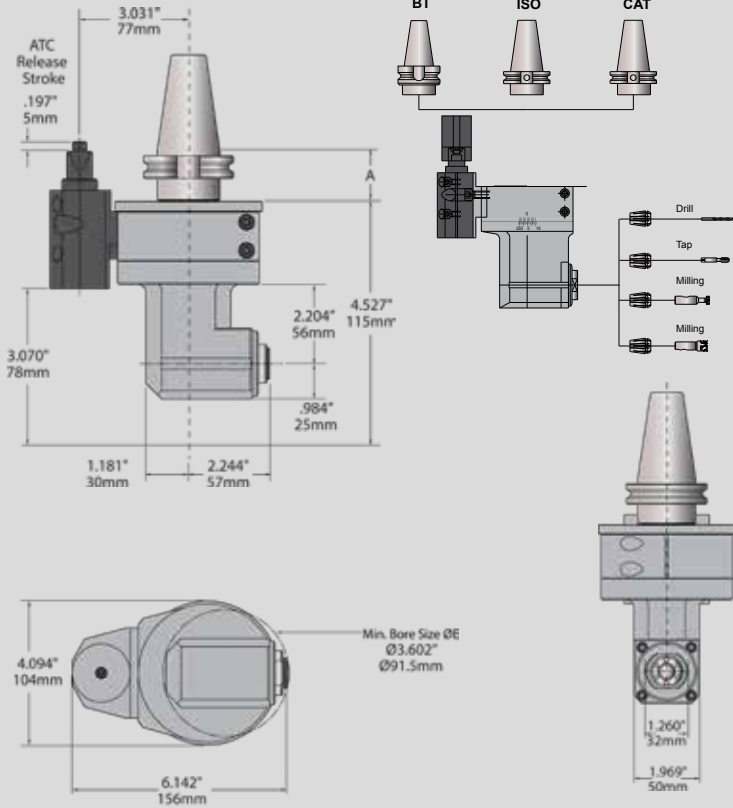

### Interchangeable Modular Taper Holders

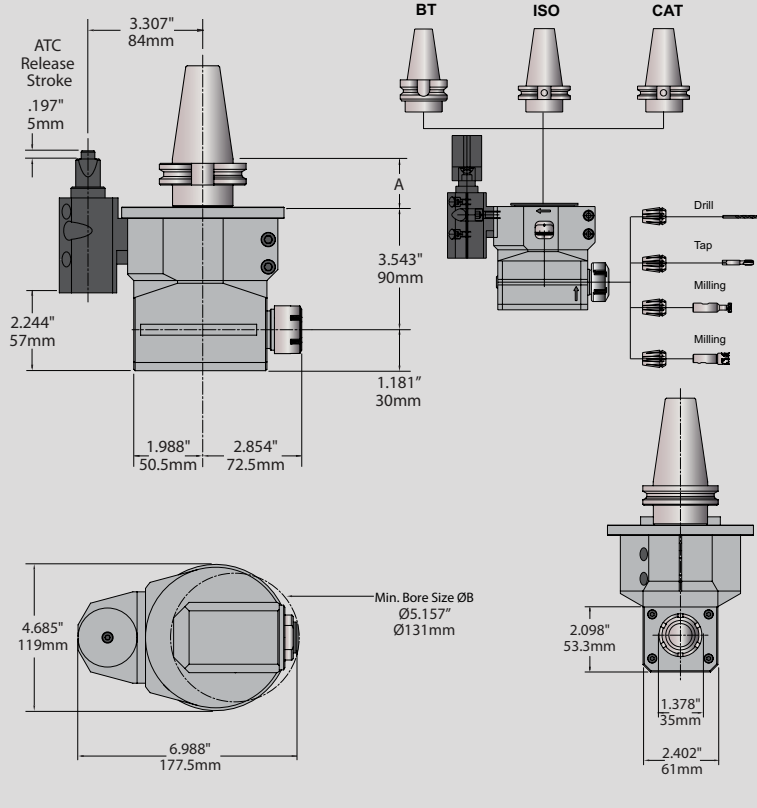

	UPC #	Description	Shank Style	Torque lb.ft	Driving Ratio	Max RPM	A Gage Line	Collet Size	Max. Tool Cap. Dia.	Max. Tap Size	*Max Slotting Cutter I.D.	**Weight	List Price	Promo
ER16	45966-Z20A2	90CNC-AAH-ER16-40DIN69871	ISO40-DIN69871	4.8	1 to 1	4000	1.378	ER16	0.375	0.312		14.3	\$5,019.52	<b>\$4,500</b>
	45967-Z20A2	90CNC-AAH-ER16-BT40	BT40				1.457							
	45968-Z20A2	90CNC-AAH-ER16-CAT40	CAT40				1.378							
	45970-Z20A2	90CNC-AAH-ER16-50DIN69871	ISO50-DIN69871				1.457							
	45971-Z20A2	90CNC-AAH-ER16-BT50	BT50				2.047							
	45972-Z20A2	90CNC-AAH-ER16-CAT50	CAT50				1.457							
	UPC #	Description	Shank Style	Torque lb.ft	Driving Ratio	Max RPM	A Gage Line	Collet Size	Max. Tool Cap. Dia.	Max. Tap Size	*Max Slotting Cutter I.D.	**Weight	List Price	Promo
ER25	45975-Z20A2	90CNC-AAH-ER25-40DIN69871	ISO40-DIN69871	14.7	1 to 1	3500	1.378	ER25	0.625	0.625	1.250	14.3	\$5,811.13	<b>\$5,225</b>
	45976-Z20A2	90CNC-AAH-ER25-BT40	BT40				1.457							
	45977-Z20A2	90CNC-AAH-ER25-CAT40	CAT40				1.378							
	45979-Z20A2	90CNC-AAH-ER25-50DIN69871	ISO50-DIN69871				1.457							
	45980-Z20A2	90CNC-AAH-ER25-BT50	BT50				2.047							
	45981-Z20A2	90CNC-AAH-ER25-CAT50	CAT50				1.457							

\*check the max tool size and weight capacity of your machine

# RIGHT ANGLE HEADS

with Interchangeable Modular Taper Holders

## ER32 Series Collet System

- Fixed 90° angle head with 0- 360° circular rotation
- Automatic tool change capability
- Made In Italy

## CAT40 Series Collet System

- Engineered to accept any CAT, ISO, or BT-40 taper holder
- Fixed 90° angle head with 0- 360° circular rotation
- Automatic tool change capability
- Made In Italy

Up to  
**10%**  
off!

### Interchangeable Modular Taper Holders

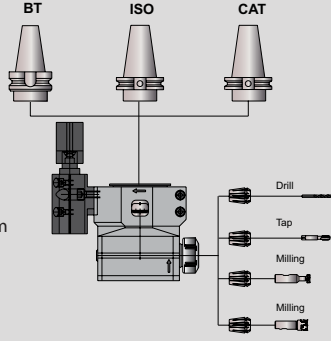

### Interchangeable Modular Taper Holders

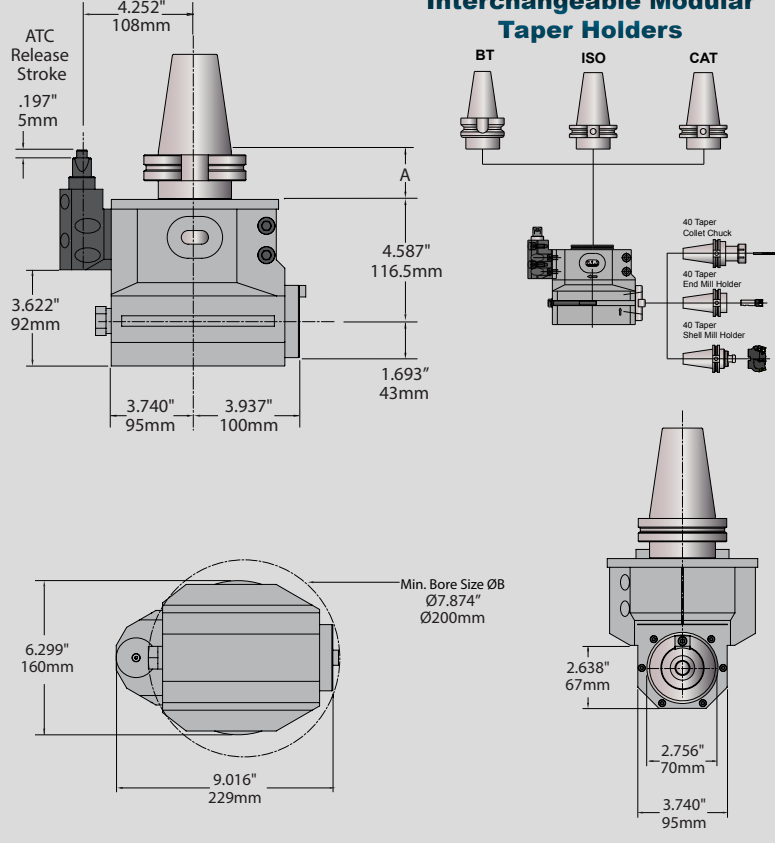
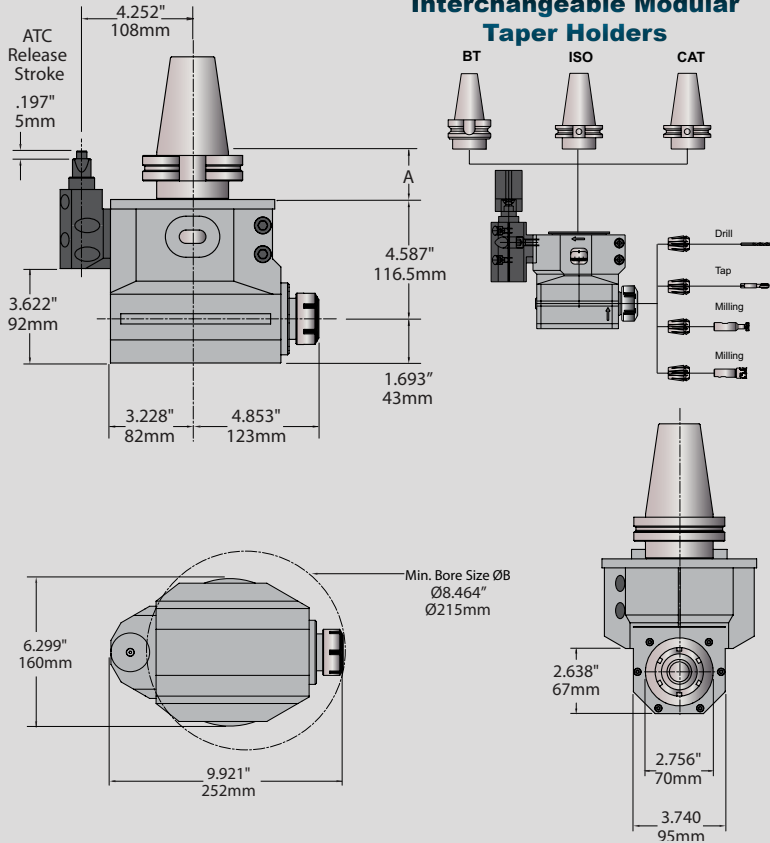
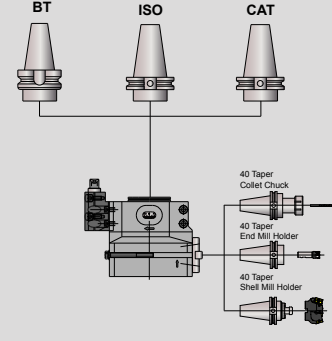

	UPC #	Description	Shank Style	Torque lb. ft	Driving Ratio	Max RPM	A Gage Line	Collet Size	Max. Tool Cap. Dia.	Max. Tap Size	*Max Slotting Cutter I.D.	**Weight (Lb)	List Price	Promo
ER32	45984-Z20A2	90CNC-AAH-ER32-40DIN69871	ISO40-DIN69871	44	1 to 1	3500	1.378	ER32	0.750	0.812	1.500	44	\$7,170.90	<b>\$6,450</b>
	45985-Z20A2	90CNC-AAH-ER32-BT40	BT40				1.457							
	45986-Z20A2	90CNC-AAH-ER32-CAT40	CAT40				1.378							
	45988-Z20A2	90CNC-AAH-ER32-50DIN69871	ISO50-DIN69871				1.457							
	45989-Z20A2	90CNC-AAH-ER32-BT50	BT50				2.047							
	45990-Z20A2	90CNC-AAH-ER32-CAT50	CAT50				1.457							
	UPC #	Description	Shank Style	Torque lb. ft	Driving Ratio	Max RPM	A Gage Line	Output	**Weight (Lb)	List Price	Promo			
CAT40	45934-Z20A2	90CNC-AAH-TP40-40DIN69871	ISO40-DIN69871	29.5	1 to 1	2000	1.378	ISO40 CAT40 BT40	44	\$7,882.56	<b>\$7,090</b>			
	45935-Z20A2	90CNC-AAH-TP40-BT40	BT40				1.457							
	45936-Z20A2	90CNC-AAH-TP40-CAT40	CAT40				1.378							
	45994-Z20A2	90CNC-AAH-TP40-50DIN69871	ISO50-DIN69871				1.457							
	45995-Z20A2	90CNC-AAH-TP40-BT50	BT50				2.047							
	45996-Z20A2	90CNC-AAH-TP40-CAT50	CAT50				1.457							

\*check the max tool size and weight capacity of your machine